

Ecosy  +
CLEAN BURNING
MULTI-FUEL WOODBURNERS



Ecosy+ Hampton 5 SE
Installation and Operating
Instructions



Version 1.1: 08/10/2018

Wood-burning Stove

Model: Ecosy+ Hampton 5kw - SE

Dimensions:

420mm wide – 335mm deep – 500mm high

SAFETY

Safety is the most important consideration when using and installing your stove. If not installed and used correctly, a house fire could result. Installation must comply with relevant national and local Building Regulations and fire safety standards.

IN THE EVENT OF A CHIMNEY FIRE, EVACUATE THE PROPERTY AND CALL THE EMERGENCY SERVICES.

Your stove will be heavy, and care needs to be taken when lifting - 2 people will normally be required to lift.

UNPACKING

Your stove will have several of its components stored inside the stove itself for transportation. The main component is the flue collar; this will simply need attaching with the provided bolts on the top, or rear of the fire. This is a Woodburning only stove, so does not require an ash pan or multi-fuel grate. All vermiculite fire bricks inside the stove must remain in place, these are not a part of the packaging.

INSTALLATION

Installation of your stove must comply with relevant local and national Building Regulations and fire safety standards. We would always suggest using a qualified installer to carry out the installation of this product. The British recognised standard for solid fuel installations is HETAS. You can find a HETAS qualified installer in your area by going to the HETAS website – www.hetas.co.uk. If you are self-installing the stove must be signed off by the local authority.

TECHNICAL

Hampton 5kw - Performance Test Results.

Weight 66kg

Total Efficiency 84 %

Nominal heat outputkW 5.00

Mean CO emission (at 13 % O₂) 0.08%

Mean flue gas temperature °C 249

Flue gas mass flow g/s 3.5

Mean NO_x emission (at 13 % O₂) Nmg/m³ - 87

DIN Plus particulates (at 13 % O₂) Nmg/m³ - 13

Mean CnHm emission (at 13 % O₂) Nmg/m³ – 63

Suitable for a direct air feed / Sealed air – 100mm spigot on the stoves rear.

Distances to combustibles:

Back Wall – Including heat shield (optional extra) 300mm

Back Wall – without heat shield. 375 mm from the rear most point on the stove. If you purchase and fit the rear flue box as an optional extra the distance to combustibles will be 375 mm from the back of this box.

Side Wall – 550mm

Hearth Temperatures

Maximum hearth temperature – 66c

This stove is suitable for a 12mm hearth

Your stove will require a constant air supply and should not be used at the same time and in the same room/space as extractor fans or any device which may draw air supply away from the stove. The stove should be installed on a level floor with adequate load bearing capacity. The stove does include adjustable feet for levelling.

Normally for most houses in the UK no extra ventilation is required when installing a stove rated at 5kW or less.

Note: The requirements regarding ventilation have been updated in the most recent version of the Building Regulations and are now based on the air permeability of the house.

The stove is NOT suitable for installation in a shared flue system.

If installed in a standard type chimney, a register plate needs to be fitted inside the chimney.

When purchasing flexible flue liner, or twin walled flue, 6" diameter is required if the Defra stop is not fitted. If the Defra stop is in place a 5" liner or twin walled flue can be installed. It is against the law to install a 5" liner on a woodburning stove unless it has the required Defra fitting in place. The flue pipe must be fitted INSIDE the flue spigot and sealed with a generous amount of Fire Cement.

Access should be provided for cleaning the flue to ensure that the passageways for exhaust gases remain free from obstruction.

OPTIONAL EXTRAS

- Heat shield – This can be bolted to the stoves rear and reduces distances to combustibles at the back of stove from 375mm to 300mm. The heat shield cannot be used at the same time as the flue box (below) The standard 125mm flue collar that comes with the stove can be used.
- Vertical Flue Box – This flue box can be bolted to the stoves rear and enables you to position the stove further into the room; away from the wall. This box can make installations easier and does not push the stove out as far as 90-degree T pieces. The flue box cannot be used at the same time as the heat shield (above)

OPERATING INSTRUCTIONS

Regulations

All National and local regulations, including those referring to national and European standards, need to be complied with when installing the stove.

The Clean Air Act 1993 and Smoke Control Areas

Under the Clean Air Act local authorities may declare the whole or part of the district of the authority to be a smoke control area. It is an offence to emit smoke from a chimney of a building, from a furnace or from any fixed boiler if located in a designated smoke control area. It is also an offence to acquire an “unauthorised fuel” for use within a smoke control area unless it is used in an “exempt” appliance (“exempted” from the controls which generally apply in the smoke control area).

In England appliances are exempted by publication on a list by the Secretary of State in accordance with changes made to sections 20 and 21 of the Clean Air Act 1993 by section 15 of the Deregulation Act 2015. Similarly, in Scotland appliances are exempted by publication on a list by Scottish Ministers under section 50 of the Regulatory Reform (Scotland) Act 2014. In Northern Ireland appliances are exempted by publication on a list by the Department of Agriculture, Environment and Rural Affairs under Section 16 of the Environmental Better regulation Act (Northern Ireland) 2016. In Wales appliances are exempted by regulations made by Welsh Ministers.

Further information on the requirements of the Clean Air Act can be found here:

<https://www.gov.uk/smoke-control-area-rules>

The Ecosy+ - Hampton 5 SE has been recommended as suitable for use in smoke control areas when burning seasoned wood logs. The appliance has a factory-fitted modification to the secondary air control to prevent closure beyond 3.25mm open position.

Your local authority is responsible for implementing the Clean Air Act 1993 including designation and supervision of smoke control areas and you can contact them for details of Clean Air Act requirements.

Please note the following advice on minimising smoke emissions:

Refuelling on to a low fire bed

If there is insufficient burning material in the fire bed to light a new fuel charge, excessive smoke emission can occur. Refuelling must be carried out onto a sufficient quantity of glowing embers and ash that the new fuel charge will ignite in a reasonable period. If there are too few embers in the fire bed, add suitable kindling to prevent excessive smoke.

Fuel overloading

The maximum amount of fuel specified in this manual should not be exceeded, overloading can cause excess smoke.

FUEL

Wood- All types of wood are suitable provided they are well seasoned, UNTREATED, and have a moisture level between 12% and 20%. For soft woods, typically they will need to have been left in suitable storage for 9+ months for the moisture to evaporate. For hardwoods, this will usually be 18 months+. It is recommended that logs should be no more than 5" (125mm) in diameter and 8" (200mm) in length.. If you are unsure of the moisture content of your fuel, then you can buy a moisture meter which will indicate the moisture levels in your fuel. Liquid fuels must NEVER be used. WARNING: Wet timber should not be used as this will create excess tar deposits in the chimney and stove and could increase the risk of chimney fire. Timber which is not of a suitable moisture content will also create more smoke and harmful emissions, and will damage the stove and flue system.

AIR INLET CONTROLS

Base lever - This controls the Secondary/Airwash and Tertiary burn system. Air is drawn through the rear and is fed over the fire through a series of holes above the bricks and on the baffle itself. This helps to burn off the initial smoke and gasses produced by the fire, prior to it going up the chimney. Air also flows past these holes and is fed over the glass, helping it to keep clean and clear of smoke stains. When the lever is pulled towards you, more air is fed into the fire, pushed away from you decreases the amount of air into the fire.

When the Defra screw is activated this air vent is set such that the closure plate does not seal fully, thus allowing some constant air supply into the stove. This is a feature of all Defra "SE" stove

Below image: For the stove to be compliant with Defra standards, this screw must be fully wound in. This is required if you are in a smoke free zone or want to install a 5" liner or chimney system

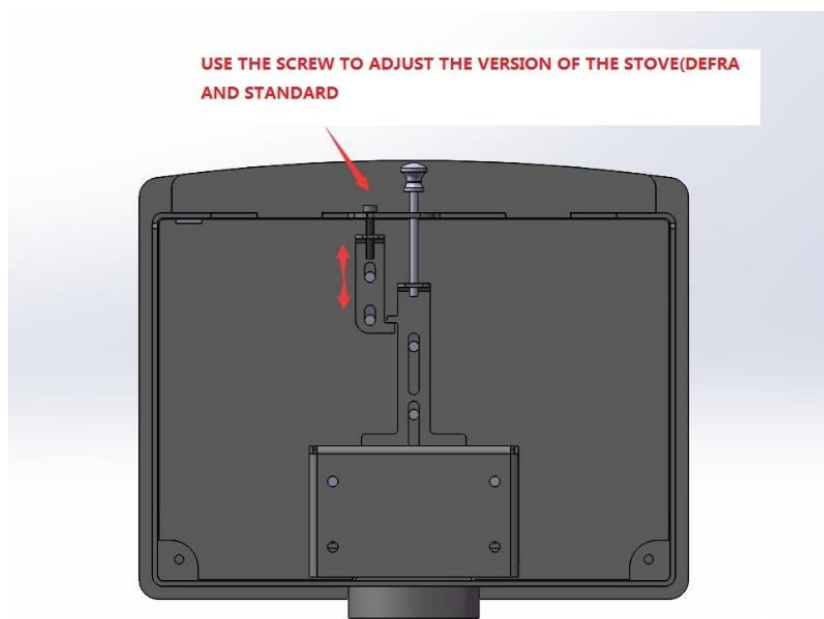

TOOLS

The glove is provided for adjusting the air inlets and for opening the door when the stove is hot, as these knobs will heat up when in use. NOTE – all parts of the stove will become hot during use and care needs to be taken to avoid injury through burning.

LIGHTING THE FIRE AND RE-FUELING

- ☑ Prior to lighting the fire for the first time, ensure that-
- ☑ Installation and building work is complete.
- ☑ The chimney is suitable and sound and has been swept and free from obstruction.
- ☑ Adequate ventilation and provision for combustion air has been made.
- ☑ That the stove installation has been carried out in accordance with Building Regulations and any applicable local regulations as well as these installation instructions.
- ☑ That chimney draw has been checked and within specification. (The stove has been tested at nominal output with a flue draught of 12 Pa)

ESSENTIAL INSTRUCTIONS BEFORE USE – It is essential to follow these ‘tempering-in’ instructions in order to avoid serious damage to your stove. The castings of your stove require very gentle ‘normalising’ to release stresses in the metal formed during the casting process. The paint finish also requires an initial curing process to be followed: -

For the initial tempering/ curing period, ensure the tertiary air inlet is set to MINIMUM, by pushing the lever to the left but ensuring it is not fully closed. For the first 2 burns on day one just use small controlled kindling wood fires with each fire lasting around 40 minutes – the second fire can be started when the stove is almost cooled down after the first. A third slightly hotter medium type fire should then be lit using smallish logs and lasting around 1 hour. Then for the next week or around 15-20 hours total burn time, fires must be gently increased in temperature and log size and load. A stove thermometer will be a valuable tool in helping you to achieve this safely and also to ensure an efficient burn rate in future. Starting a large fire too soon is likely to damage the stove in which case it will not be covered by the warranty. Note: the paint on any new stove is relatively soft. As such do not clean, wash or wipe the surface until the paint has fully cured. Never wipe the stove whilst warm. If the above advice is ignored, then there is a high risk of the paint being “shocked” by excessive heat and could peel. Furthermore, if the stove is over fired it will invalidate your guarantee.

ENSURE THAT YOU HAVE READ AND UNDERSTOOD THESE INSTRUCTIONS BEFORE LIGHTING THE FIRE, AND THAT YOU ARE CONFIDENT THE STOVE HAS BEEN INSTALLED CORRECTLY.

ALWAYS WEAR A PROTECTIVE GLOVE WHEN REFUELLING YOUR STOVE.

Ignition (FOLLOW INITIAL TEMPERING INSTRUCTIONS ABOVE FIRST TO AVOID DAMAGE)

- ☑ Construct a pile of kindling in the middle of the bed using approx 500g of kindling wood
- ☑ Light with a single chemical firelighter
- ☑ Partially shut the door but leaving it cracked open slightly

- ☒ After about 5 minutes or when the fire is well established, shut the door
- ☒ After a further 3-5 minutes as the fire starts to die, add a further three larger pieces of wood weighing approx. 0.75kg in total.
- ☒ Once these logs are alight, and after about 7 minutes or so, a normal load of 2 logs weighing up to 1.2kg in total can be added.
- ☒ Once this load is burning well the stove can be controlled with the lever

First use troubleshooting.

When the stove is new the paint is very tacky where the stove is curing. The door locks very tight and when opened can pull away the fire rope from its chamber. If the instructions are followed above this should not happen. However, if it does the rope will need to be stuck back in place with “heat resistant fire rope glue” After a few burns the paint will be cured and this should no longer happen.

Refuelling

Every stove will work slightly differently depending on the chimney, or flue system it is attached to. It can take time to get use to the stove and how best to run and control it in each situation.

- ☒ At nominal power output, your stove will require refuelling approximately every hour.
 - ☒ It is important to follow these instructions in order to achieve clean burning and to maximise the efficiency of the stove
 - ☒ Do not leave the fire unattended until flames are well established on the newly charged logs
 - ☒ Always refuel onto hot embers.
 - ☒ If the fire has died out at the point of refuelling, use kindling to re-establish the fire and follow the “Ignition” procedure above.
 - ☒ It is important that the stove is not overloaded with fuel.
 - ☒ Reduced burn rates can be achieved by reducing the openings of the Secondary and Tertiary air vents.
 - ☒ Refuelling on to a low fire bed – If there is insufficient burning material in the firebed to light a new fuel charge, excessive smoke emission can occur.
- Refuelling must be carried out onto a sufficient quantity of glowing embers and ash that the new fuel charge will ignite in a reasonable period. If there are too few embers in the fire bed, add suitable kindling to prevent excessive smoke.
- Fuel overloading - The maximum amount of fuel specified in this manual should not be exceeded, overloading can cause excess smoke.
- Operation with door left open – Operation with the door open can cause excess smoke. The appliance must not be operated with the door left open except as directed in the instructions.
- Air controls left open
- Operation with the air controls or appliance dampers open can cause excess smoke. The appliance must not be operated with air controls, appliance dampers or door left open except as directed in the instructions.

WARNING- The high temperature paint covering the stove will give off some fumes during the initial few uses of the stove. The fumes are non-toxic, but some people may find them unpleasant – Ensure the area is well ventilated during this period.

Under certain abnormal weather conditions, e.g. down draughts, it may be difficult to get sufficient draw through the appliance to achieve good combustion. When this happens, the stove should not be used.

IMPORTANT: -

As of October 2010, it is a legal requirement to use a Carbon Monoxide Detector in the same room as the stove. This needs to incorporate a battery which lasts the life of the detector.

CLEANING/MAINTENANCE

When cold, the inside of the stove should be given a regular sweep out.

The flue and flue pipe will require cleaning with a suitable chimney brush, to minimise build-up of soot and tar. Your chimney will also require periodic sweeping.

If the glass becomes stained from the inside, the air-wash vent may need opening more during use. The high temperature paint which your stove is finished in should last many years with normal use, but when it does eventually require re-finishing, black heat resistant paint in spray cans can be purchased from most hardware stores but we would suggest using "Calfire flat black paint". – Do not use regular paint which is not high temperature resistant. After prolonged periods of not using the fire, the stove and flue system should be checked for blockages prior to relighting. We recommend regular servicing and safety checks are carried out by a qualified engineer. There must be no unauthorised modification of the appliance. Use only replacement parts recommended by the manufacturer.

MODELS WITH MIRROR GLASS: THIS GLASS HAS A SPECIAL COATING, DO NOT USE ANY ABRASIVE MATERIAL TO CLEAN THE GLASS. Just use a clean cloth with warm water when the stove is cold, if you clean the glass when it is still warm the glass can "craze", crazing can also occur if incorrect fuels are burnt on the stove, or fuels with impurities in them. **If fire bricks have just split, they do not need replacing. The bricks only need replacing when they have fully crumbled away exposing the stoves rear or sides. Fire bricks are fully heat resistant but can easily split if struck with a log**

GUARANTEE

The main body of your stove is guaranteed for 7 years. This does not include broken glass, Crazed glass, fire bricks, door seals, paint and over-firing

Incorrect use or installation not carried out by a registered HETAS installer will void the guarantee. The only exceptions will be if the install has been signed off by your local authority. Please keep hold of the invoice as this will be requested if a claim started, if this is not provided upon request, we will not be able to escalate your claim. The guarantee will begin from the sale date on the invoice and we do not cover any cost incurred when removing faulty appliances or installing new ones, even if it has been proven that the stove is faulty. For full guarantee details please visit www.ecosystoves.co.uk

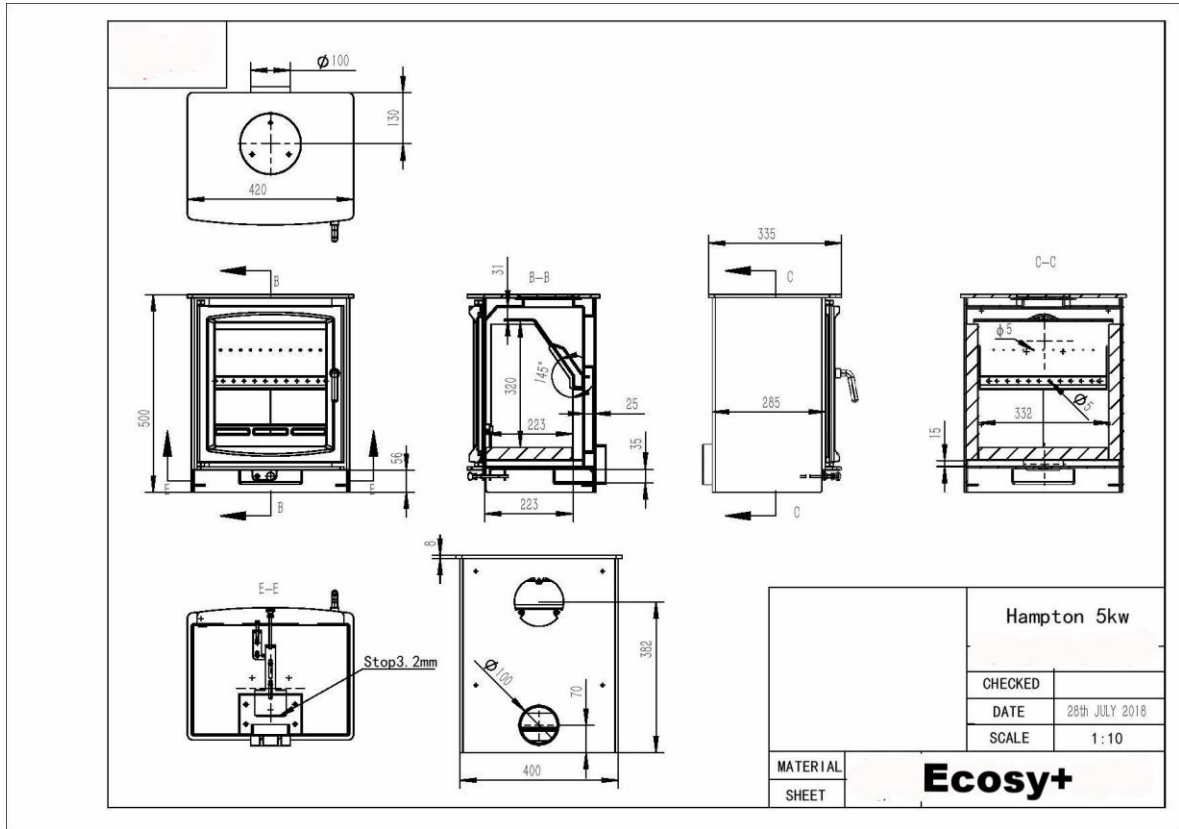

-Ecosy+, Unit 22-26 – Folly farm, Ramsdell, Tadley, RG26 5GJ



ENERG Y IJA
енергия · ενεργεια
IE IA

Ecosy+

Hampton 5

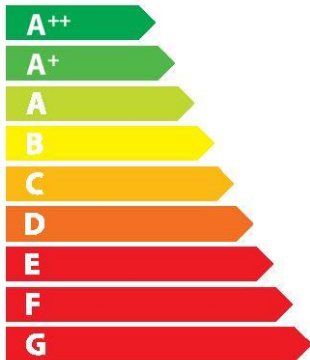

A+

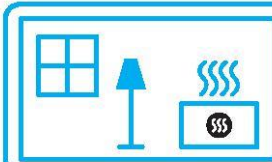

5,0
kW

ENERGIA · ЕНЕРГИЯ · ΕΝΕΡΓΕΙΑ · ENERGIJA · ENERGY · ENERGIE · **ENERGI**

2015/1186